

ACCESSORIES

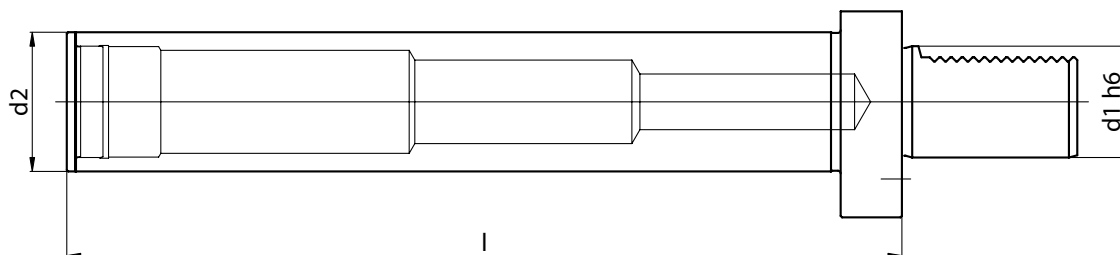



Code N.	Description	d1	d2	l
118-51601	VDI 16 D25 L200	16	25	200
118-52002	VDI 20 D30 L220	20	30	220
118-52501	VDI 25 D30 L220	25	30	220
118-53002	VDI 30 D40 L230	30	40	230
118-54003	VDI 40 D50 L300	40	50	300
118-55002	VDI 50 D50 L300	50	50	300
118-56002	VDI 60 D60 L300	60	60	300
118-58001	VDI 80 D70 L350	80	80	350

IM HOLZKASTEN UND MIT PRÜFUNGSBESCHEINIGUNG
 SUPPLIED IN WOODEN BOXES AND WITH TEST CERTIFICATE
 FOURNIES EN BOÎTES DE BOIS ET AVEC CERTIFICAT DE CONTRÔLE
 FORNITE IN CASSETTA DI LEGNO E CON CERTIFICATO DI COLLAUDO



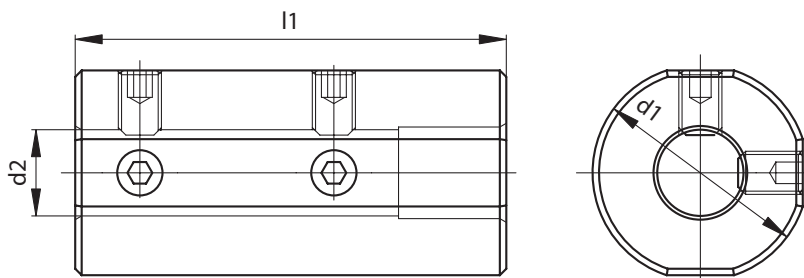

Code N.(metric)	d1	d2	l1
E2-1-20x6	20	6	60
E2-1-20x8	20	8	60
E2-1-20x10	20	10	60
E2-1-20x12	20	12	60
E2-1-25x6	25	6	60
E2-1-25x8	25	8	60
E2-1-25x10	25	10	60
E2-1-25x12	25	12	60
E2-1-32x6	32	6	70
E2-1-32x8	32	8	70
E2-1-32x10	32	10	70
E2-1-32x12	32	12	70
E2-1-32x16	32	16	70
E2-1-32x20	32	20	70
E2-1-40x6	40	6	80
E2-1-40x8	40	8	80
E2-1-40x10	40	10	80
E2-1-40x12	40	12	80
E2-1-40x16	40	16	80
E2-1-40x20	40	20	80
E2-1-40x25	40	25	80
E2-1-50x12	50	12	90
E2-1-50x16	50	16	90
E2-1-50x20	50	20	90
E2-1-50x25	50	25	90
E2-1-50x32	50	32	90
E2-1-60x16	60	16	160
E2-1-60x20	60	20	160
E2-1-60x25	60	25	160
E2-1-60x32	60	32	160
E2-1-60x40	60	40	160

**REDUZIERHÜLSE, MORSEKEGEL
ADAPTOR, MORSE TAPER
DOUILLE DE REDUCTION, CONE MORSE
BUSSOLA DI RIDUZIONE CONO MORSE**

E2-3

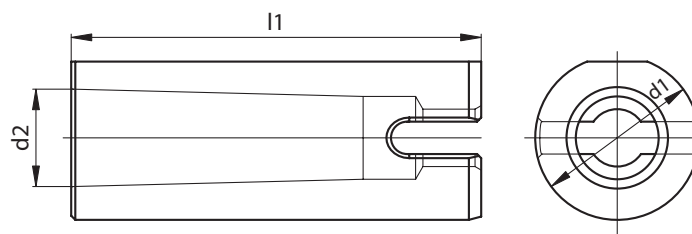

Code N.	d1	MK	d2	l1
E2-3-20x1	20	1	12.065	60
E2-3-20x2	20	2	17.780	90
E2-3-32x1	32	1	12.065	60
E2-3-32x2	32	2	17.780	90
E2-3-32x3	32	3	23.825	100
E2-3-40x2	40	2	17.780	90
E2-3-40x3	40	3	23.825	100
E2-3-40x4	40	4	31.267	120
E2-3-50x2	50	2	17.780	90
E2-3-50x3	50	3	23.825	100
E2-3-50x4	50	4	31.267	120
E2-3-60x3	60	3	23.825	160
E2-3-60x4	60	4	31.267	160
E2-3-60x5	60	5	44.399	160

**M.K. REDUZIERHÜLSE, MIT ANSCHLAG
MORSE TAPER ADAPTER
DOUILLE DE REDUCTION, CONE MORSE
BUSSOLA DI RIDUZIONE CONO MORSE CON BATTUTA**

114

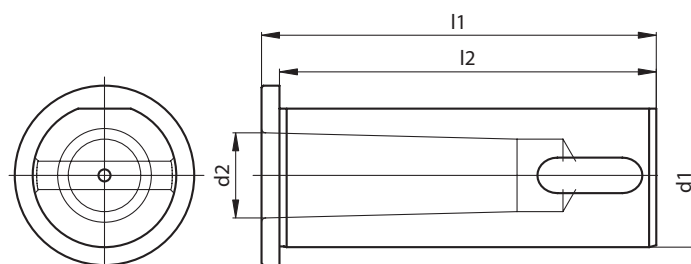

Code N.	d1	MK	d2	l1	l2
114-33208	32	1	12.065	90	85
114-33209	32	2	17.780	90	85
114-33210	32	3	23.825	100	95
114-34008	40	2	17.780	110	105
114-34009	40	3	23.825	110	105
114-34010	40	4	31.267	125	120
114-35004	50	2	17.780	130	125
114-35005	50	3	23.825	130	125
114-35006	50	4	31.267	130	125
114-36007	60	3	23.825	140	130
114-36008	60	4	31.267	140	130
114-36009	60	5	44.399	155	145

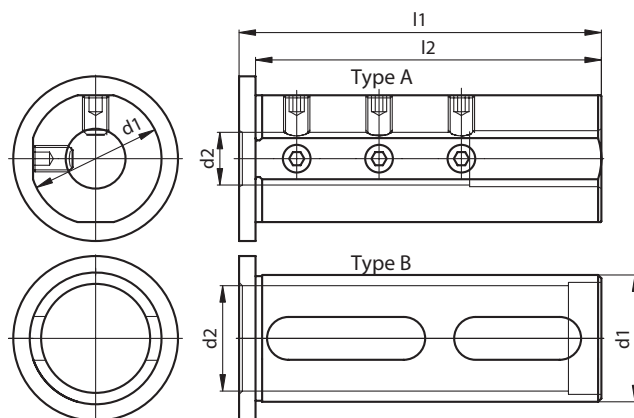

Code N.	d1	d2	l1	l2	Type
115-62573	25	6	65	60	A
115-62538	25	8	65	60	A
115-62539	25	10	65	60	A
115-62540	25	12	65	60	A
115-62541	25	16	65	60	B
165-63222	32	6	90	85	A
115-63260	32	8	90	85	A
115-63261	32	10	90	85	A
115-63211	32	12	90	85	A
115-63212	32	16	90	85	A
115-63213	32	20	90	85	A
115-63214	32	25	90	85	B
165-64074	40	6	110	105	A
115-64043	40	8	110	105	A
115-64044	40	10	110	105	A
115-64045	40	12	110	105	A
115-64046	40	16	110	105	A
115-64047	40	20	110	105	A
115-64048	40	25	110	105	A
115-64049	40	32	110	105	B
115-65053	50	12	130	125	A
115-65013	50	16	130	125	A
115-65014	50	20	130	125	A
115-65015	50	25	130	125	A
115-65016	50	32	130	125	A
115-65017	50	40	130	125	B
115-66017	60	20	140	135	A
115-66018	60	25	140	135	A
115-66019	60	32	140	135	A
115-66020	60	40	140	135	A
115-66021	60	50	140	135	B
115-68006	80	25	150	145	A
115-68007	80	32	150	145	A
115-68008	80	40	150	145	A
115-68009	80	50	150	145	A
115-68010	80	60	150	145	B

ZYLINDRISCHE REDUZIERHÜLSE MIT ANSCHLAG
TOOL HOLDER BUSHING
DOUILLE DE REDUCTION CYLINDRIQUE
BUSSOLA DI RIDUZIONE CILINDRICA CON BATTUTA, TAGLIATA

RZ

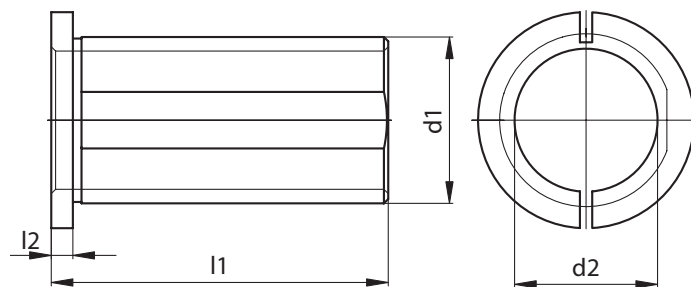

Code N.	d1	d2	l1	l2
RZ-20x08	20	8	30	4
RZ-20x10	20	10	30	4
RZ-20x12	20	12	30	4
RZ-20x16	20	16	30	4
RZ-25x08	25	8	40	4
RZ-25x10	25	10	40	4
RZ-25x12	25	12	40	4
RZ-25x16	25	16	40	4
RZ-25x20	25	20	40	4
RZ-32x08	32	8	50	4
RZ-32x10	32	10	50	4
RZ-32x12	32	12	50	4
RZ-32x16	32	16	50	4
RZ-32x20	32	20	50	4
RZ-32x25	32	25	50	4
RZ-40x10	40	10	78	4
RZ-40x12	40	12	78	4
RZ-40x16	40	16	78	4
RZ-40x20	40	20	78	4
RZ-40x25	40	25	78	4
RZ-40x32	40	32	78	4
RZ-50x20	50	20	88	4
RZ-50x25	50	25	88	4
RZ-50x32	50	32	88	4
RZ-50x40	50	40	88	4
RZ-60x25	60	25	92	4
RZ-60x32	60	32	92	4
RZ-60x40	60	40	92	4
RZ-60x50	60	50	92	4

ZYLINDRISCHE REDUZIERHÜLSE MIT ANSCHLAG FÜR BOHRSTANGENHALTER TYP E2 E2-115
CYLINDRICAL BUSHING FOR BORING BAR HOLDERS TYPE E2
DOUILLES DE REDUCTION CYLINDRIQUES POUR PORTE-BARRES D'ALEPAGE E2
BUSSOLA DI RIDUZIONE CILINDRICA CON BATTUTA, PER PORTABARENTI E2

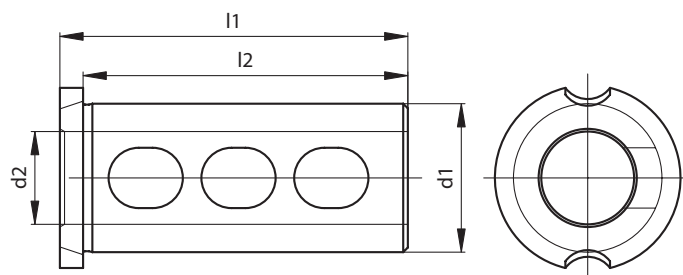

Code N.	d1	d2	l1	l2	E2 Type		
115-62574	25	8	52	47	E2-25x25		
115-62575		10					
115-62576		12					
115-62577		16					
115-62578		20					
115-62579		8				62	57
115-62580		10					
115-62581		12					
115-62582		16					
115-62583		20					
115-62584		8	75	70	E2-60x25		
115-62585		10					
115-62586	12						
115-62587	16						
115-62588	20						
165-63223	32	8				62	57
165-63224		10					
165-63225		12					
165-63226		16					
165-63227		20					
165-63228		25	75	70	E2-60x32		
165-63229		8					
165-63230		10					
165-63231		12					
165-63232		16					
165-63233		20				62	57
165-63234		25					
165-64075	8						
165-64076	10						
165-64077	12						
165-64078	16						
165-64079	20						
165-64080	25	75	70	E2-50x40			
165-64081	32						
165-64082	8						
165-64083	10						
165-64084	12						
165-64085	16						
165-64086	20						
165-64087	25						
165-64088	32						

SPANNZANGENAUFNAHMEN MIT ZENTRALSCHMIERUNG
COLLET CHUCKS WITH COOLANT HOLES
PORTE-PINCES AVEC ARROSAGE CENTRAL
PORTAPINZE CON FORI DI LUBRIFICAZIONE

NC

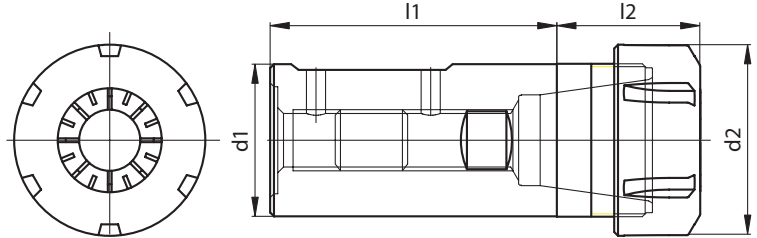

Code N.	Description	Range	d1	d2	l1	l2
214-35170	NC32L60ER25	1-16	32	42	60	32
214-35171	NC32L60ER32	2-20	32	50	60	38
214-35172	NC40L75ER32	2-20	40	50	75	38
214-35173	NC40L75ER40	3-26	40	63	75	55

VERSCHLUßSTOPFEN
BLANKING PLUG
BOUCHON DE PROTECTION
TAMPONE DI PROTEZIONE

Z2

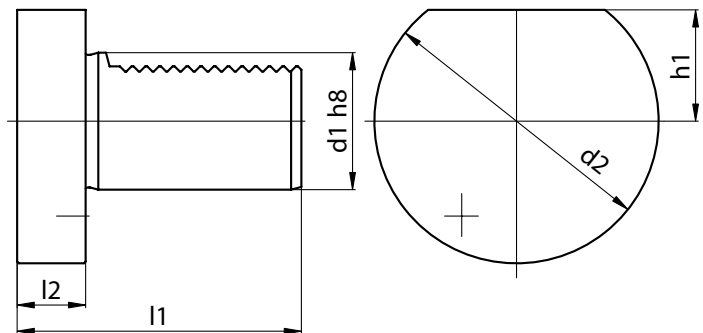

Code N.	d1	d2	h1	l1	l2
Z2-16 S/P	16	40	18	45	13
Z2-20 S/P	20	50	23	56	16
*Z2-25 S	25	58	25	64	16
Z2-30 S/P	30	68	28	71	16
Z2-40 S/P	40	83	32.5	83	20
Z2-50 S/P	50	98	35	98	20
Z2-60 S/P	60	123	42.5	114	20
Z2-80 S/P	80	158	55	144	20

• Lieferbar sowohl aus Stahl als auch aus Plastik
 * Plastik Z2-25S nur aus Stahl

• Available either in plastic or in steel
 * Z2-25S is only available in steel

• Disponible soit en acier soit en plastique
 * Z2-25S seulement en acier

• Fornibili sia in acciaio sia in plastica
 * Z2-25S fornibili solo in acciaio

S =	Stahl Steel Acier Acciaio	P =	Plastik Plastic Plastique Plastica
------------	------------------------------------	------------	---

WERKSTOFFANSCHLAG MIT ZYLINDERSCHAFT
CYLINDRICAL BAR STOP
PORTE-BUTEES CYLINDRIQUES
FERMOBARRA CILINDRICI

CW

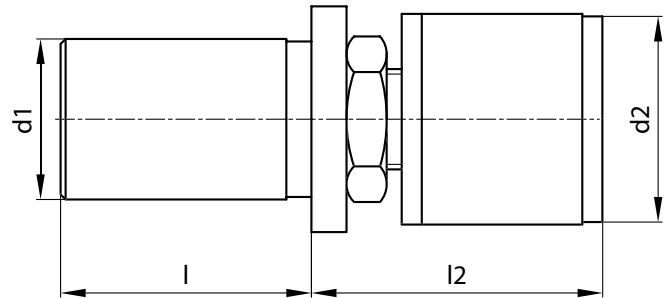

Code N.	d1	d2	l1	l2
CW-1620	16	20	32	36-62
CW-2034	20	34	50	65-100
CW-2534	25	34	50	65-100
CW-3042	30	42	50	55-90
CW-3242	32	42	50	55-90
CW-4042	40	42	50	55-90

WERKSTOFFANSCHLAG MIT ZYLINDERSCHAFT GEDÄMPFT
CYLINDRICAL REVOLVING BAR STOP WITH SHOCK ABSORBER
PORTE-BUTEES, CYLINDRIQUES, AMMORTISEES
FERMOBARRA CILINDRICI AMMORTIZZATI

CW-AM

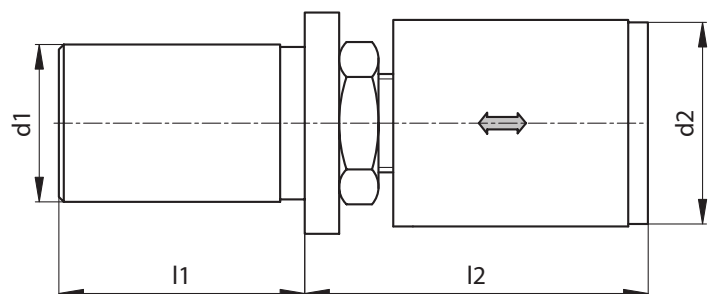

Code N.	d1	d2	l1	l2
CW-2542-AM	25	42	50	62-97
CW-3042-AM	30	42	50	62-97
CW-3242-AM	32	42	50	62-97
CW-4042-AM	40	42	50	62-97

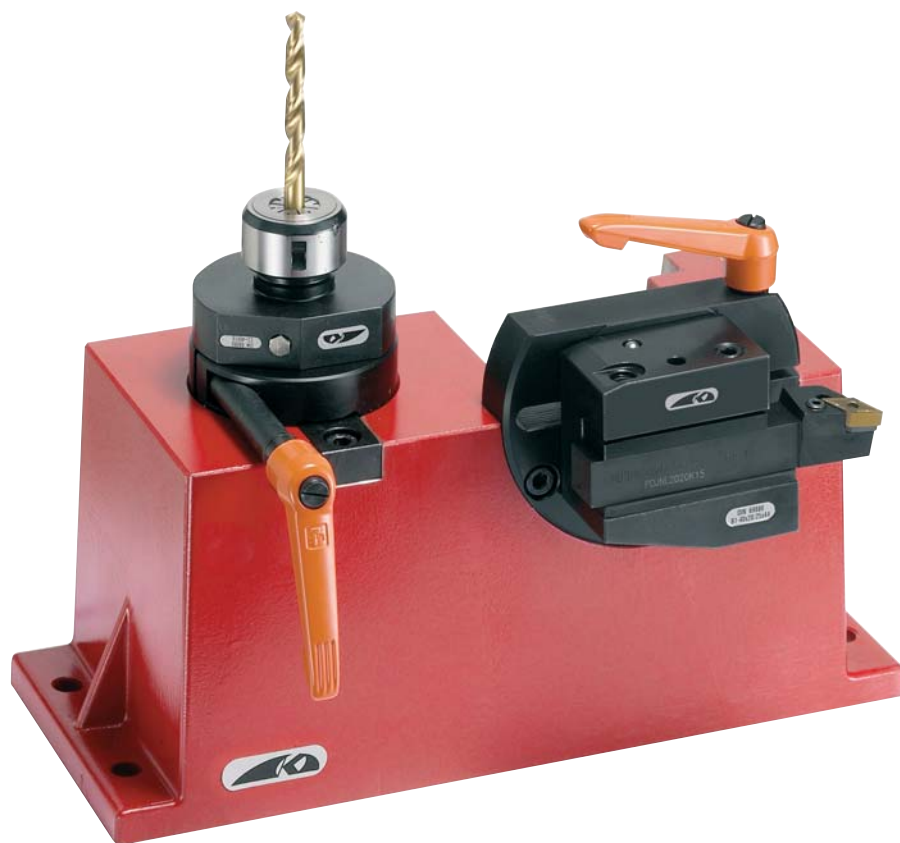

VDI	Code N.
16	237-32190
20	237-32290
25	237-32390
30	237-32490
40	237-32590
50	237-32690
60	237-32790
80	237-32890

Dieses unkomplizierte System erlaubt die schnelle Montage und Demontage von VDI Werkzeughaltern (gemäß DIN 69880) in horizontaler und vertikaler Lage. Das ist ein sehr einfach System für das Handling des Werkzeuges.

This system allows the assembly and disassembly operations of the VDI toolholders in horizontal and Vertical position. This is a very simple system for tool handing.

Il permet d'effectuer toutes les operations de montage et de démontage des porte outils VDI (DIN 69880) soit en horizontal qui en vertical. Ce système est très simple à utiliser pour la manipulation des outils.

Questo sistema molto semplice consente il montaggio e lo smontaggio dei portautensili VDI (secondo la normativa DIN 69880) sia in orizzontale che in verticale.

È un sistema che offre la massima semplicità d'uso per la manipolazione degli utensili.

DISCHI PORTA UTENSILI

Costruiti con macchine CNC e controllati con sistemi tridimensionali. Possiamo offrire:

- dischi portautensili con sedi VDI secondo DIN 69880 sia assiali che radiali completi di tassello di chiusura.
- Dischi portautensili a sedi quadre, reversibili completi di tasselli di chiusura e sedi quadre per portautensili longitudinali.
- Dischi portautensili con sedi predisposte ad alloggiamento clamping di chiusura speciali (HSK - Capto - KM etc...) sia assiali che radiali.

DISKS

Made with CNC machines and checked with three dimensional instruments. We can offer:

- disks with VDI seat (Norm 69880) both axial and radials, complete with stop plug.
- Disks with square seats, reversible, and complete with stop plugs and square seats for longitudinal toolholders
- Disks arranged with seats for special clamping (HSK, CAPTO, KM etc...) both axial and radial.



REVOLVERSCHEIBE

Mit NC Maschine gefertigt und mit 3D Meßgeräte kontrolliert.

Wir bieten folgendes an:

- Revolverscheibe zur Aufnahme von VDI Werkzeughalter (axial und radial)
- Revolverscheibe mit Vierkantaufnahmen (längst und radial)
- Sonderrevolverscheibe zur Aufnahme von HSK/Capto/KM und sonstiges.



DISQUE PORTE-OUTILS

Construits avec CN machines et contrôlés avec des systèmes tridimensionnels. Nous pouvons vous offrir:

- Disques porte-outils avec sièges VDI selon Norme DIN 69880, soit axiaux que radials completes de tasseau de fermeture
- Disques porte-outils avec sièges carrés, réversibles, completes avec tasseaux de fermeture et sièges carrés pour porte-outils longitudinal.
- Disques porte-outils avec sièges prévues pour le logement de "clamping spéciales": Hsk
- Capto - Km etc... soit axiales que radiales.



PINZE ALLOGGIAMENTO PORTAUTENSILI PER MAGAZZINI MACCHINE UTENSILI

Grazie alla nostra costante ed intensa collaborazione con i più famosi costruttori di macchine utensili, abbiamo sviluppato una buona esperienza nella produzione di Pinze ad alta precisione per l'alloggiamento nei magazzini di macchine utensili.

Nella nostra gamma sono presenti attacchi: ISO, HSK, Capto, Km ed altri, e naturalmente siamo aperti ad altre versioni secondo disegno del cliente.



DISKS

Thanks to our constant and exhaustive co-operation with the most famous machine tool makers we develop a very good experience into the manufacturing of high precision clamping fingers for toolmagazines. Our range includes clampers for the most popular attachments: ISO CONES, HSK, Capto or KM Holders but of course we are open to any new version, according to the customer's drawing.



GREIFER FÜR WERKZEUGMAGAZIN

Dank unserer intensiven und engen Zusammenarbeit mit den berühmtesten Maschinenhersteller Europas haben wir eine sehr gute Erfahrung auch in dem Bereich Magazinkassetten entwickelt. Gerne bieten wir Ihnen folgende Ausführungen: für ISO, HSK, CAPTO, KM und alle andere, nach Ihrem Wunsch.



PINCES DE LOGEMENT POUR LE MAGASIN DES MACHINES OUTILS

Grâce à notre constant et intensif collaboration avec les plus célèbres constructeurs des machine outils, nous avons développé une bonne expérience pour la production de pinces de logement pour le magasin des machines outils.

Dans notre gamme il y a attachements: ISO, HSK, Capto, Km et autres. Naturellement nous sommes ouvert à construire autres type de pinces suite aux différents plans du client.

